
**OWNER'S (OPERATOR'S) MANUAL
AND SAFETY INSTRUCTIONS
FOR CF SERIES CHAIN HOIST (MODEL CF4)**

BEFORE USING THIS PRODUCT :

ALWAYS SAVE THIS BOOK FOR FUTURE REFERENCE

ALWAYS READ OWNER'S (OPERATOR'S) MANUAL AND SAFETY INSTRUCTIONS

- ▲ WARNING** : **IMPROPER** chain hoist use could result in death or serious injury. To avoid these hazards:
- : **NEVER** hoist loads over or near people.
 - : **NEVER** work under or near hoisted loads.
 - : **ALWAYS** operate, inspect and maintain this hoist in accordance with applicable safety codes and regulations.

These safety instructions contain important information to help you use the chain hoist in a safe manner. Please refer to this Owner's (Operator's) Manual for additional safety information.

CONTENTS

DEFINITION	1
1. BEFORE USE	1
1.1 Safety Summary	1
1.2 Safety Instructions	2
2. MAIN SPECIFICATIONS	5
3. OPERATION	6
3.1 Safety Consideration	6
3.2 Operation	6
3.3 Hoist Storage	6
4. INSPECTION	7
4.1 Outline	7
4.2 Daily Inspection	7
4.3 Periodic Inspection	8
5. MAINTENANCE	13
5.1 Lubrication	13
5.2 Overhaul, Assembly and Adjustment	14
6. WARRANTY	21
7. PARTS LIST	22

DEFINITION

⚠ WARNING : indicates a potentially hazardous situation which, if not avoided, could result in death or serious injury.

1. BEFORE USE

1.1 Safety Summary

Danger exists when heavy loads are transported, particularly when the equipment is not being used properly or is poorly maintained. Because accidents and serious injury could result, special safety precautions apply to the operation, maintenance and inspection of the Manual Chain Hoist.

Following these simple rules can help to avoid hoisting accidents;

⚠ WARNING : **IMPROPER** chain hoist use could result in death or serious injury. To avoid these hazards:

NEVER use a hoist for lifting, supporting or transporting people.

NEVER lift or transport loads over or near people.

NEVER work near or under hoisted loads.

NEVER lift more than rated load.

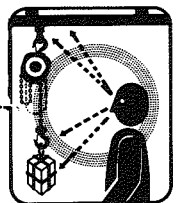
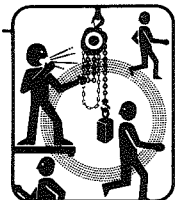
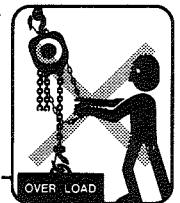
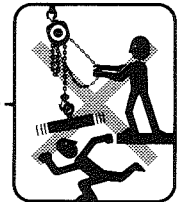
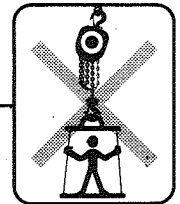
ALWAYS let people around you know when a lift is about to begin.

ALWAYS make sure that the supporting structures and load-attaching device are strong enough to hold the weight of the load and hoist.

ALWAYS read Owner's (Operator's) manual and safety instructions.

Remember, proper rigging and lifting techniques are the responsibility of the operator. Be sure to read and understand the instructions contained in this manual before using your hoist. Check all applicable safety codes, regulations and other applicable laws for further information about the safe use of your hoist.

More detailed safety information is contained in the following pages. For additional information, please contact Kito Corporation or your authorized Kito dealer.



1.2 Safety Instructions

Serious injury could result if the following safety instructions are not followed.

⚠ WARNING : **IMPROPER chain hoist use could result in death or serious injury. To avoid these hazards:**

“ALWAYSs”

- ALWAYS** make sure that you and others are clear of the load before lifting begins.
- ALWAYS** allow only qualified (trained in safety and operation) people to operate the hoist.
- ALWAYS** operate a hoist only if you are physically fit.
- ALWAYS** check the hoist before daily use according to the Recommended Daily Inspection (Refer to Sec. 4.2).
- ALWAYS** let the authorized personnel inspect the hoist periodically (Refer to Sec. 4.3).
- ALWAYS** make sure that the chain length is long enough for the intended job.
- ALWAYS** check that the hook latches are in proper working order before use (Refer to Sec. 4.3).
- ALWAYS** replace all missing or broken hook latches.
- ALWAYS** be sure that the hoist's rated capacity, which is found on the hoist's label, is well in excess of the weight of the load.
- ALWAYS** be sure that the load is properly seated in the saddle of the hook.
- ALWAYS** keep the load from hitting the chain.
- ALWAYS** use two hoists which have rated capacities equal to or more than the load to be lifted whenever you must use two hoists to lift a load. This will provide adequate protection in the event that a sudden load shift or failure of one hoist occurs.
- ALWAYS** check the brake before use (Refer to Sec. 4.3).
- ALWAYS** check for loose or missing parts before use.
- ALWAYS** lubricate the hoist regularly (Refer to Sec. 5.1).
- ALWAYS** pay attention to the load at all times when operating the hoist.
- ALWAYS** ease the slack out of the chain and sling when starting a lift to prevent a sudden loading.

ALWAYS secure a hoist and loads properly after use.

ALWAYS consult the manufacturer or your dealer if you plan to use a hoist in a dusty, moist or greasy environment.

ALWAYS consult the manufacturer or your dealer if you plan to use a hoist in an excessively corrosive environment.

ALWAYS operate the hoist with manual power.

⚠ WARNING : **IMPROPER chain hoist use could result in death or serious injury. To avoid these hazards:**

“NEVERs”

NEVER use the hoist to transport people.

NEVER lift a load over people.

NEVER work near or under hoisted loads.

NEVER operate a hoist if damaged or malfunctioning.

NEVER use a hoist which has been taken out of service until the hoist has been properly repaired or replaced.

NEVER use a hoist if the hook latch is missing or broken.

NEVER lift a load unless it is directly under the hook.

NEVER splice a hoist chain.

NEVER use non-authentic KITO chains on the hoist.

NEVER use the hoist chain as a sling.

NEVER force a chain or hook into place by hammering.

NEVER jerk a load to prevent a sudden loading.

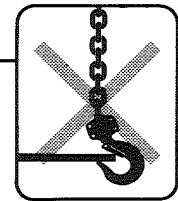
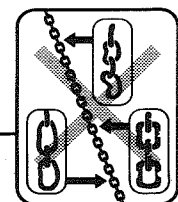
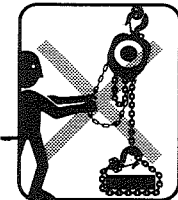
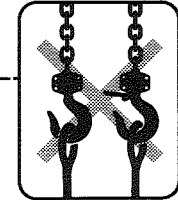
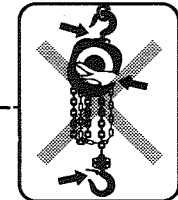
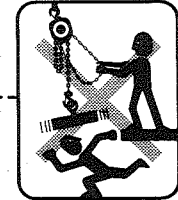
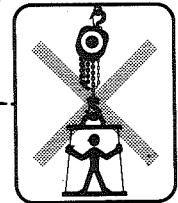
NEVER use a twisted, kinked, damaged or stretched load chain.

NEVER swing a suspended load.

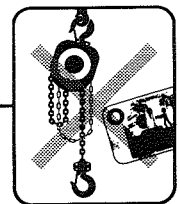
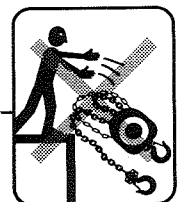
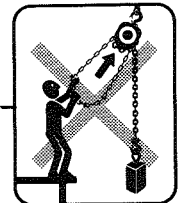
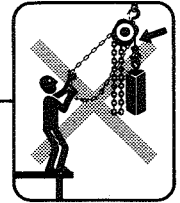
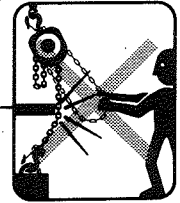
NEVER support a load on the tip of the hook.

NEVER suspend a load for an extended period of time.

NEVER leave a suspended load unattended.



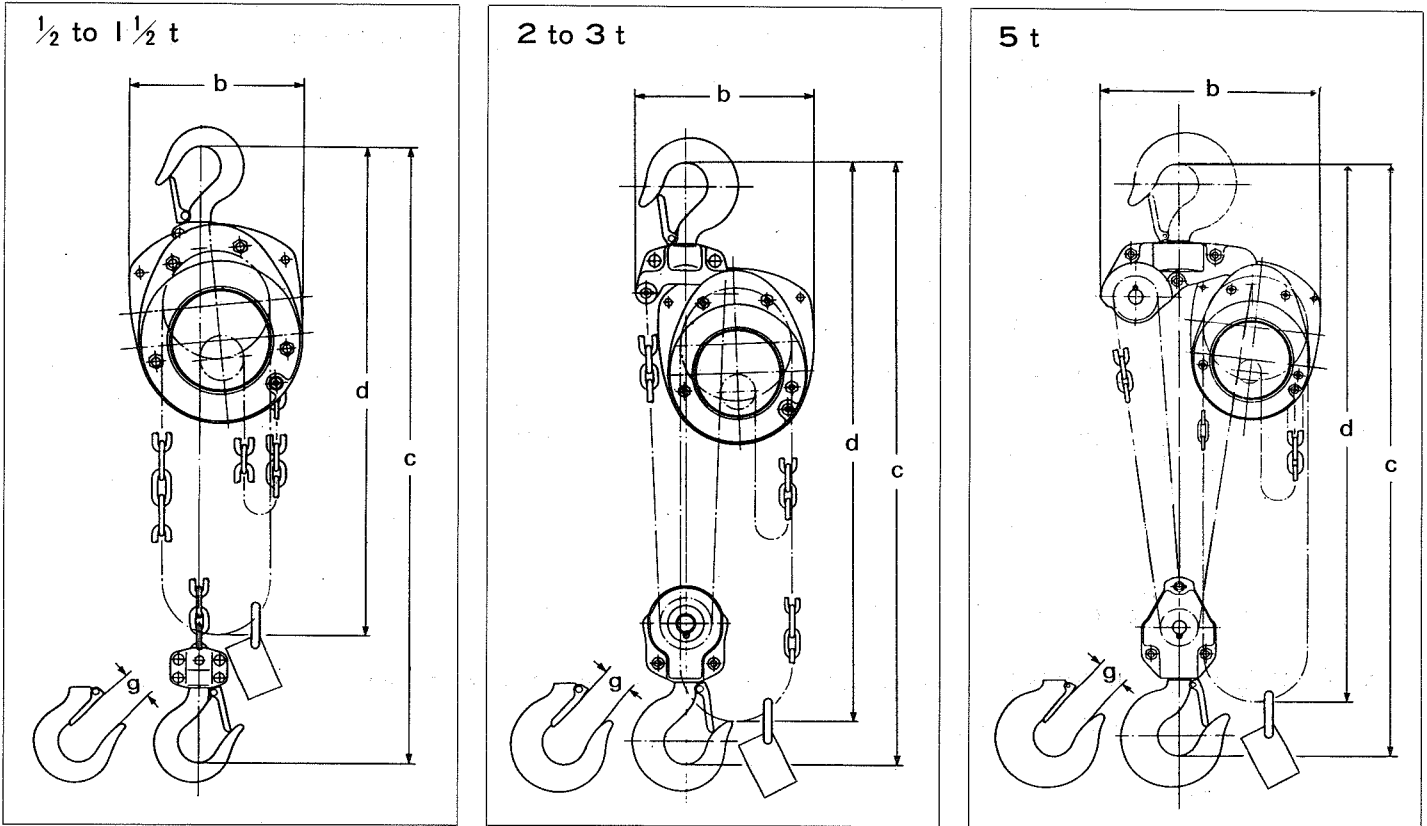
- NEVER** run the load chain over a sharp edge. -----
- NEVER** weld or cut a load suspended by a hoist.
- NEVER** use the hoist chain as a welding electrode.
- NEVER** use the hoist with rusty chain.
- NEVER** wind so far that the hook touches the block.-----
- NEVER** unwind so far that no unloaded chain is left.-----
- NEVER** operate a hoist if chain jumping, excessive noise, jamming, overloading or binding occurs.
- NEVER** use a hoist without chain stopper (or tail pin) at the end of no load side chain.-----
- NEVER** throw a hoist.-----
- NEVER** use a hoist without a name plate or warning tag and label or with illegible name plate, warning tag and label.-----
- NEVER** remove or obscure the warning tag. -----
- NEVER** use modified or deformed hooks.
- NEVER** use a motor to operate a manual hoist.
- NEVER** use a hoist near fire or where hot objects may touch it.
- NEVER** use the hoist in temperature below -40°C (-40°F) or above $+60^{\circ}\text{C}$ ($+140^{\circ}\text{F}$).



WARNING TAG is installed on a hand chain.

2. MAIN SPECIFICATIONS

Unit system is the metric one (SI unit system) in the following table.



Model	Code	Nominal Capacity (t)	Std. Lift (m)	Min. Distance between Hooks: C (mm)	Chain Pull to Lift Full Load (kg)	Chain O'hailed to Lift Load One Meter (m)	Test Load (kg)	Net Weight (kg)	Shipping Weight (Approx) (kg)	Load chain Dia (mm) × Fall(lines)	Weight in kg for Additional One Meter of Lift (kg)	b (mm)	d (mm)	g (mm)
CF4	CF005	½	2.5	325	30	19	750	10	11	5.0×1	1.5	150	2.5	27
CF4	CF010	1	2.5	370	36	31	1500	12	13	6.3×1	1.8	174	2.5	29
CF4	CF015	1½	2.5	440	42	41	2360	17	18	7.1×1	2.1	203	2.5	34
CF4	CF020	2	3.0	510	40	63	3000	21	22	6.3×2	2.7	204	3.0	36
CF4	CF030	3	3.0	590	46	81	4750	28	30	7.1×2	3.2	240	3.0	42.5
CF4	CF050	5	3.0	620	46	134	6300	37	39	7.1×3	4.3	342	3.0	46.5

- Any lift of chain is available on request. Because KITO chains are specially heat-treated, only authentic KITO chains should be used on your hoist. **Never** attempt to lengthen your chain by attaching additional chain links with any other means. KITO can supply almost any length of chain desired. Simply specify the length of chain desired when ordering.

3. OPERATION

3.1 Safety Consideration

⚠ WARNING : IMPROPER operation could result in death or serious injury. To avoid these hazards, only operate the chain hoist by hand. Power operation may result in structural damage or premature wear. This damage or wear may cause a part to break and cause the load to fall.

3.2 Operation

1. Face the hand chain wheel side of the hoist.
2. To raise the load, pull hand chain clockwise.
3. To lower the load, pull hand chain counterclockwise.

NOTE: The clicking sound of the pawl when a load is being raised indicates normal operation.

3.3 Hoist Storage

⚠ WARNING : IMPROPER chain hoist use could result in death or serious injury. To avoid these hazards:

ALWAYS store the hoist in no load condition.

ALWAYS wipe off all dirt and water.

ALWAYS oil the chain, top pin, chain pin and hook latches.

ALWAYS hang in a dry place.

ALWAYS check the hoist for abnormalities when using the hoist after a period of non-use according to the regular inspection procedures (Refer to Sec.4.3).

4. INSPECTION

4.1 Outline

There are two types of inspection, the daily inspection performed by the operator while using the hoist, and the more thorough periodic inspections performed by qualified personnel who have the authority to remove the unit from service.

4.2 Daily Inspection

Before each work shift, check the following points:

- (1) Check that the name plate showing the hoist capacity is attached and clearly legible.
- (2) Check that the warning tag and label are attached and clearly legible.
- (3) Check for visual defects or abnormal noises which could indicate a defect.
- (4) Check that the upper and lower hook latches are in place and in proper condition.
- (5) Make sure the openings of the top and bottom hooks are not too wide, that the swivel rotates freely and that the hook latch is in position and works normally.
- (6) Check for wear or damage, increased throat width, bent shank or bending of hook.
- (7) Check that the chain does not have excessive rust or corrosion and that it is not dry due to lack of lubricant.
- (8) When facing the hand chain side of the hoist with no load : The brake is operating normally if the pawl "clicks" when the hand chain is wound in a clockwise direction and does not "click" when operated in the counterclockwise direction.
- (9) Check lubrication and lubricate if necessary (Refer to Sec.5.1).
- (10) Check that the chain is assembled normally and that there is no twisting.
- (11) Check for loose or missing nuts and for missing split pins.

4.3 Periodic Inspection

Periodic inspections should be made at the interval shown below and should follow the given procedures.

NORMAL (Normal use): Semiannual inspection
 HEAVY (Frequent use): Quarterly inspection
 SEVERE (Excessively frequent use): Monthly inspection

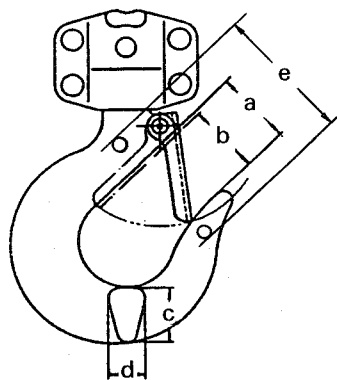
<Regular Inspection Procedure>

Figures in parentheses are Figure Nos. in Parts List.

Item	Inspection Method	Discard Limit/Criteria	Measures
Indications	Check visually.	○ Capacity indication is clear.	Attach the name plate.
HOOK [1,4,44,56,66,75] (Top and Bottom)			
1. Deformation/ twist of hook opening	Measure dimension "e" between two embossed marks at time of purchase with calipers. Check visually.	○ No deformation from original shape (at time of purchase). ○ Twist shall not be large enough to detect visually.	Replace the hook. Replace the hook.
2. Wear	Measure "c" and "d" with slide calipers.	○ Never use the hook if dimension "c" or "d" becomes less than 90% of normal.	Replace the hook.

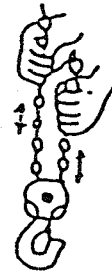


Table 1
(Reference dimensions)



Type (t)	a (mm)		b (mm)		c (mm)		d (mm)	
	Normal	Discard	Normal	Discard	Normal	Discard	Normal	Discard
½	31.0	17.0	27.0	15.3	12.1	10.9		
1	34.0	21.8	29.0	19.6	16.0	14.4		
1½	37.5	26.5	34.0	23.9	19.5	17.6		
2	40.0	30.0	36.0	27.0	21.8	19.6		
3	46.0	37.5	42.5	33.8	27.2	24.5		
5	50.0	47.5	46.5	42.8	34.5	31.1		

Item	Inspection Method	Discard Limit/Criteria	Measures
3. Hook flaws	Check visually.	○ No great damage permitted.	Replace the hook.
4. Hook movement	Turn hook.	○ Shall turn smoothly.	Replace the hook.
5. Upper/lower fixture damage [Fittings of 1,4,44,56,66,75]	Check visually.	○ No slack or missing rivets, nuts or bolts.	Replace the hook.
6. Idle sheave rotation [55,61,70]	Hold the load chain with both hands and turn the idle sheave by moving the chain up and down.	○ Smooth rotation.	Overhaul.
7. Hook latch [2,6,45,57,67,76]	Check visually.	○ Proper positioning and smooth working.	Replace the latch or hook.



LOAD CHAIN
[42]

1. Wear

Measure with slide calipers.

○ Measure the sum of pitches of five chain links and check that the maximum length does not exceed value shown in table 2.

Replace the chain.

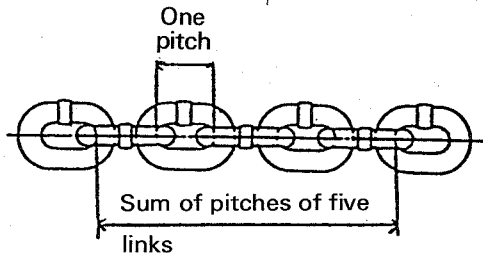


Table 2

Type (t)	Sum of pitches of five links (mm)	Discard limit (mm)
½	75.5	77.7
1, 2	95.5	98.3
1½, 3, 5	106.0	109.1

2. Rust, flaws, deformation

Check visually.

○ No obvious rust (Apply oil as necessary.)
○ No twists or harmful flaws.

Remove rust.
Replace the load chain.

HOOK YOKE

(Top set [1,44,66]
Bottom set [4,56,75])

Joint of upper/lower fixtures with top pin [3] and chain pin [7,46]

Measure hole diameter of joint area in two directions at right angle.

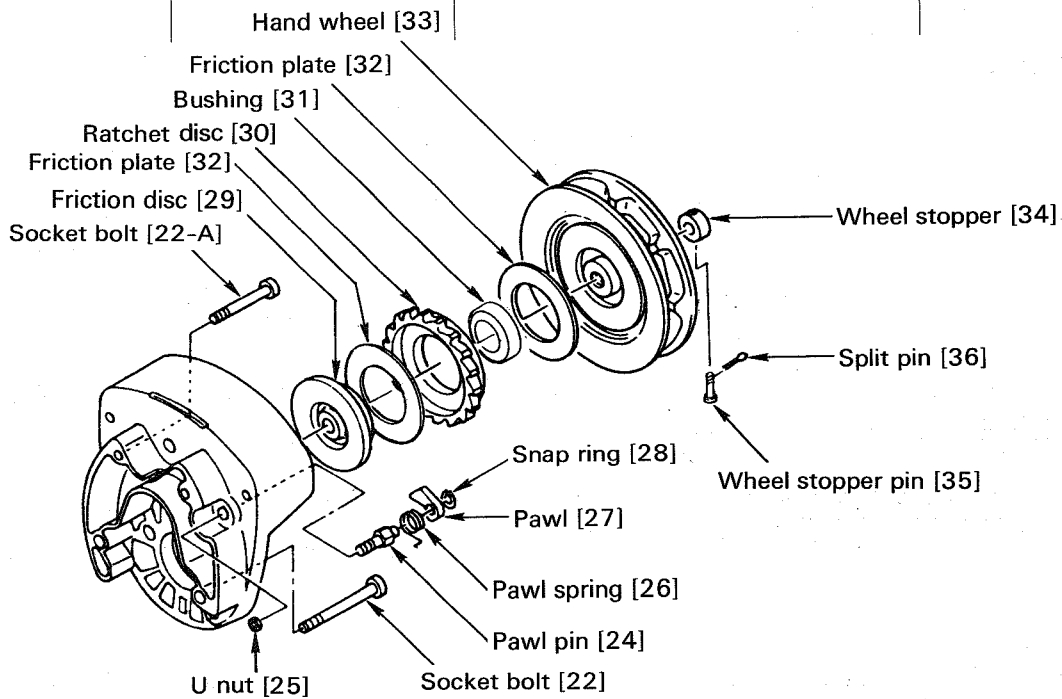
○ Deformation not permitted (if each measured value differs more than 0.5mm, it is not a circle).

Replace the part.

Item	Inspection Method	Discard Limit/Criteria	Measures
FUNCTION 1. Lifting and lowering 2. Brake	Lift and lower a light load.	<ul style="list-style-type: none"> ○ No abnormal difficulty in lifting or lowering. ○ Confirm that none of the problems listed below occur during lifting and lowering: <ul style="list-style-type: none"> • Lifting impossible. • Load falls when the operator removes his hands. • Load fall during unwinding. • Load slips down slowly. 	Overhaul and service. Overhaul and service.

BRAKE
(Inside mechanism)

Overhaul and check.



1. Flaws on brake surface [31,31-A,32]
2. Flaws on friction disc [29]
3. Wear on friction plate [32]

Check visually.

Check visually.

Measure with slide calipers.

○ No flaws due to scratching or gouging by foreign matter.

○ No flaws due to scratching or gouging by foreign matter.

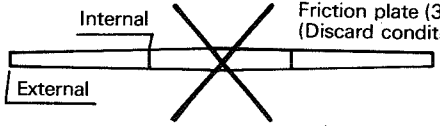
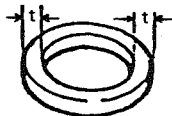
○ Retain uniform thickness and friction plate shall not be worn more than 0.5mm.

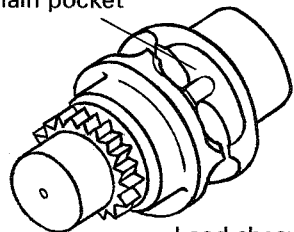
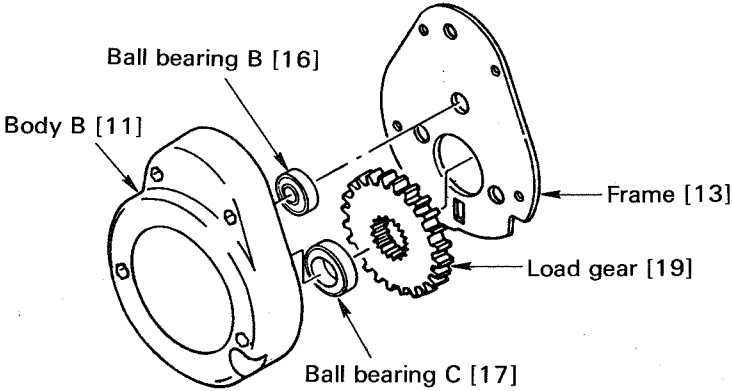
For all types;
 Normal thickness: 3 mm
 Discard limit: 2.5 mm

Replace the part.

Replace the part.

Replace the part.

Item	Inspection Method	Discard Limit/Criteria	Measures									
4. Flatness of friction plate [32]	Check clearance with straight gauge.	<ul style="list-style-type: none"> ○ Clearance shall be uniform. Internal part shall not be thicker than external part. 	Replace the part.									
5. Bushing [31]; wear and oil	Check radial thickness (t) with caliper and oil existence.	<ul style="list-style-type: none"> ○ Radial thickness (t) shall be uniform. Oil shall be contained. Refer to table 3.  <p>Bushing [31] t: Radial thickness</p> <table border="1" data-bbox="771 640 1323 892"> <caption>Table 3</caption> <thead> <tr> <th>Type (t)</th> <th>Normal thickness (t) (mm)</th> <th>Discard limit (mm)</th> </tr> </thead> <tbody> <tr> <td>1/2</td> <td>3</td> <td>2</td> </tr> <tr> <td>1, 1 1/2, 2, 3, 5</td> <td>4</td> <td>3</td> </tr> </tbody> </table>	Type (t)	Normal thickness (t) (mm)	Discard limit (mm)	1/2	3	2	1, 1 1/2, 2, 3, 5	4	3	Replace the part.
Type (t)	Normal thickness (t) (mm)	Discard limit (mm)										
1/2	3	2										
1, 1 1/2, 2, 3, 5	4	3										
6. Ratchet disc [30]; wear and rust	Check visually.	<ul style="list-style-type: none"> ○ The tooth wear shall not be more than 1.5 mm. ○ No rust. 	Replace the part.									

LIFTING SYSTEM			
1. Load sheave [18]; wear and deformation	Check visually.	<ul style="list-style-type: none"> ○ No large wear, no deformation, or no burr due to load chain contact is permitted on the surface of load chain pocket.  <p>Load sheave [18]</p>	Replace the part.
2. Gear [19]; wear and flaw	Check visually.	<ul style="list-style-type: none"> ○ Teeth shall be free from large wear or flaws. 	Replace the part.

Item	Inspection Method	Discard Limit/Criteria	Measures
3. Hand wheel [33]; wear and deformation	Check visually.	<ul style="list-style-type: none"> ○ No large wear or no deformation on the surface of hand chain pocket. ○ Turn and check if it touches the cover. 	<p>Replace the part.</p> <p>Replace the part.</p>
FRAME [13] 1. Flaw on frame	Check visually.	<ul style="list-style-type: none"> ○ No flaws or cracks. 	Replace the frame.
MISCELLANEOUS 1. Wear on chain guide [20] 2. Flaw on guide roller [20-A] 3. Deformation of stripper [21]	Check visually.	<ul style="list-style-type: none"> ○ No excessive wear or press mark is permitted. ○ Shall turn lightly. ○ No large crush or damage on stripper tip is permitted. 	<p>Replace the part.</p> <p>Replace the part.</p> <p>Replace the part.</p>

5. MAINTENANCE

⚠ WARNING : **IMPROPER chain hoist use could result in death or serious injury. To avoid these hazards:**

- : **NEVER perform maintenance on the hoist while it is supporting a load.**
- : **Before performing maintenance, attach the tag:
[“DANGER”: DO NOT OPERATE EQUIPMENT BEING REPAIRED.]**
- : **Only allow qualified service personnel to perform maintenance.**
- : **After performing any maintenance on the hoist, always test to its rated capacity before returning to service.**

5.1 Lubrication

5.1.1 Applying Grease to Gears

Remove body B (11), in the way of '5.2 Overhaul'.

Remove old grease and replace with new grease (standard grease*), at annual inspection.

Temperature range of standard grease is -40°C (-40°F) to $+60^{\circ}\text{C}$ (140°F). If the hoist is used at temperature below -40°C (-40°F) or above $+60^{\circ}\text{C}$ (140°F), consult the manufacturer or dealer since some parts shall be changed.

*Calcium soap grease equivalent of NLGI (National Lubricating Grease Institute)/ #2

5.1.2. Load Chain

⚠ WARNING : **IMPROPER chain hoist use could result in death or serious injury. To avoid these hazards:**

- : **Failure to maintain clean and well lubricated load chain will void the manufacturer's warranty.**

ALWAYS lubricate load chain weekly, or more frequently, depending on severity of service.

ALWAYS lubricate more frequently than normal in a corrosive environment.*

ALWAYS use machine oil equivalent to ISO VG46 or 68.

ALWAYS clean chain with an acid free solvent only to remove rust or abrasive dust build-up. After cleaning, lubricate the chain.

ALWAYS lubricate each link of the chain and apply new lubricant over existing layer.

*KITO has a corrosion-resistant chain as an option. For information on the capabilities and limitations of KITO's regular and corrosion-resistant chain, please ask your dealer.

5.2 Overhaul, Assembly and Adjustment

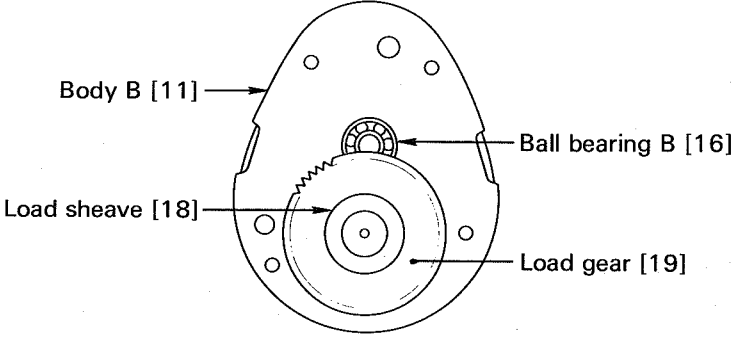
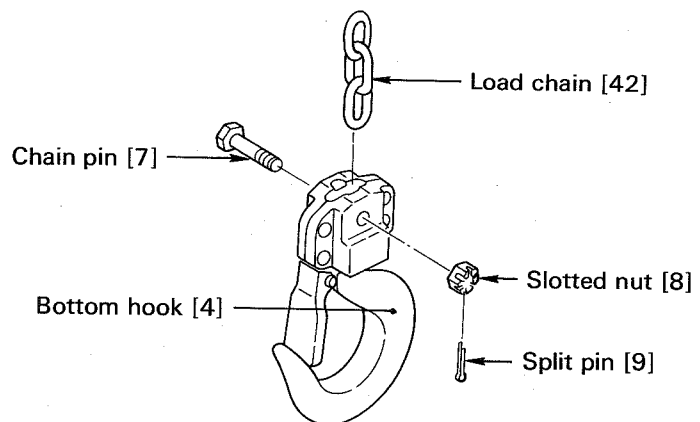
5.2.1 Overhaul

Figures in parentheses are Figure Nos. in Parts List.

Overhaul Procedures	Remarks
1. Put a hoist with wheel cover side up.	
2. Unscrew three screws [38] (with spring washers [39]) fixing the wheel cover [37].	
3. Remove the wheel cover [37] from the body A [10].	
4. Insert the vertical link of the hand chain [43] into the notch of the hand wheel [33] and remove the hand chain by turning the hand wheel counterclockwise.	Bring the notch of the hand wheel to the right hand.
5. Pull out split pin [36] from the wheel stopper pin [35] and remove the wheel stopper pin and wheel stopper [34] from the pinion [14].	
6. Remove hand wheel [33] from the pinion [14] by turning the hand wheel counterclockwise.	If the hand wheel is too tight to turn by hand, put hand chain on the hand wheel back again and pull it down hard. It will release the brake.
7. Remove two friction plates [32], ratchet disc [30] and bushing [31] from the friction disc [29].	
8. Remove the friction disc [29] from the pinion [14] by turning counterclockwise holding the end of the pinion with fingers.	
9. Remove snap ring [28] from the pawl pin [24] (on the body A [10]) and then remove pawl [27] and pawl spring [26].	
10. Unscrew the pawl pin [24].	The pawl pin is fixed with the U nut [25].
11. Unscrew four socket bolts [22, 22-A] connecting body A [10] and B [11].	Four socket bolts are fixed with U nuts [23] on the body B side.

Overhaul Procedures	Remarks
<p>12. Separate the body A [10] and B [11].</p> <p>13. Take ball bearing A [15] and C [17-A] out of the body A [10].</p> <p>14. Remove top hook [1] and top pin [3] from the body B [11].</p> <p>15. Remove pinion [14], chain guide [20] (or guide rollers [20-A]), stripper [21], tail pin [40], and load chain [42].</p> <p>16. Remove the frame [13].</p> <p>17. Take load sheave [18] out of the load gear [19].</p> <p>18. Remove the load gear [19].</p> <p>19. Unscrew tap socket bolt [41] from the body B [11].</p> <p>20. Pull split pin [9] out of the slotted nut [8] and remove the slotted nut and chain pin [7] from the bottom hook [4].</p>	<p>Remove the bearing by tapping the ball bearing A and C with a wooden hammer from the brake side.</p>

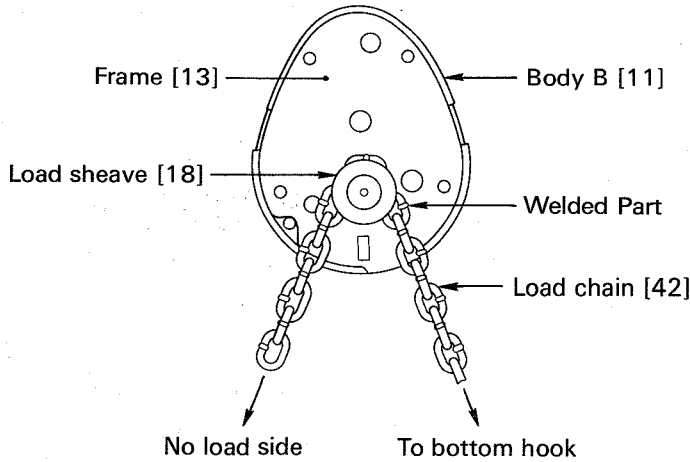
5.2.2 Assembly and Adjustment

Assembly Procedures	Remarks
<ol style="list-style-type: none">1. Wipe off old grease from the body B [11] and frame [13].2. Apply new grease to the ball bearing B [16] and C [17] on the body B [11].3. Insert load sheave [18] into the load gear [19] and put them together on the ball bearing C [17].	
 <p>The diagram shows a cross-section of a mechanical assembly. A central gear, labeled 'Load gear [19]', is mounted on a shaft. A larger gear, labeled 'Load sheave [18]', is positioned to mesh with the load gear. A ball bearing, labeled 'Ball bearing B [16]', is shown between the load gear and the body B [11]. The body B [11] is a curved, shell-like component with several small circular holes. Arrows point from the labels to the corresponding parts in the diagram.</p>	
<ol style="list-style-type: none">4. Apply new grease to the load gear [19].5. Put frame [13] on the body B [11] according to pattern.6. Insert the end of the load chain [42] to the bottom hook [4] and fix them with the chain pin [7], slotted nut [8] and split pin [9].	<p>⚠ WARNING Always bend surely the split pin.</p>
 <p>The diagram shows a mechanical assembly for attaching a load chain. A 'Load chain [42]' is shown at the top. Below it is a 'Bottom hook [4]' which is part of a larger component. A 'Chain pin [7]' is shown being inserted into the hook. A 'Slotted nut [8]' is shown being threaded onto the chain pin. A 'Split pin [9]' is shown being inserted through the slotted nut to secure it. Arrows point from the labels to the corresponding parts in the diagram.</p>	

Assembly Procedures

Remarks

- Wind load chain [42] round the load sheave [18] so that the bottom hook side comes to right hand and the end link of the other side becomes vertical to the load sheave pocket.

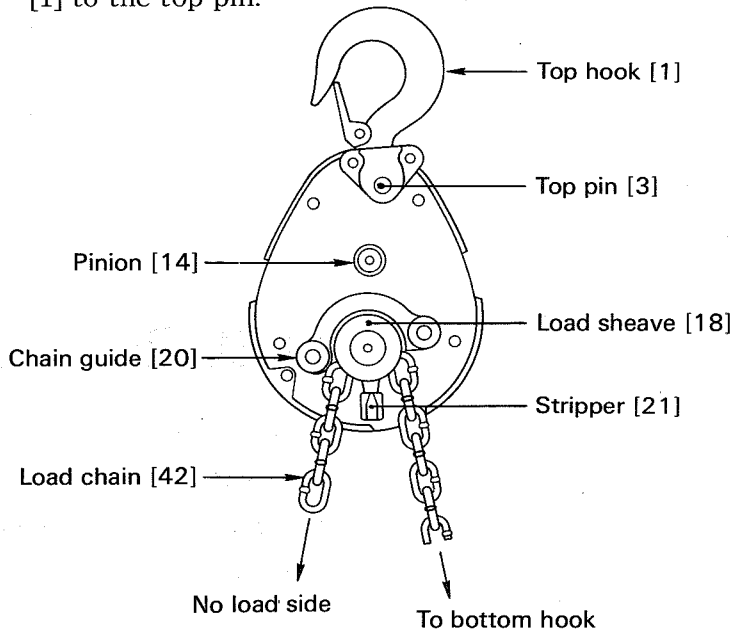


- Put chain guide [20] (or guide rollers for ½ t type [20-A]) on the frame [13].

- Put stripper [21] on the frame [13].

- Insert pinion [14] shaft from its gear side into the frame [13].

- Insert top pin [3] into the frame [13] and put top hook [1] to the top pin.



⚠ WARNING

Put the welded part of the vertical chain link outward.

⚠ WARNING

Fit the larger boss of chain guide [20] into holes on frame [13].

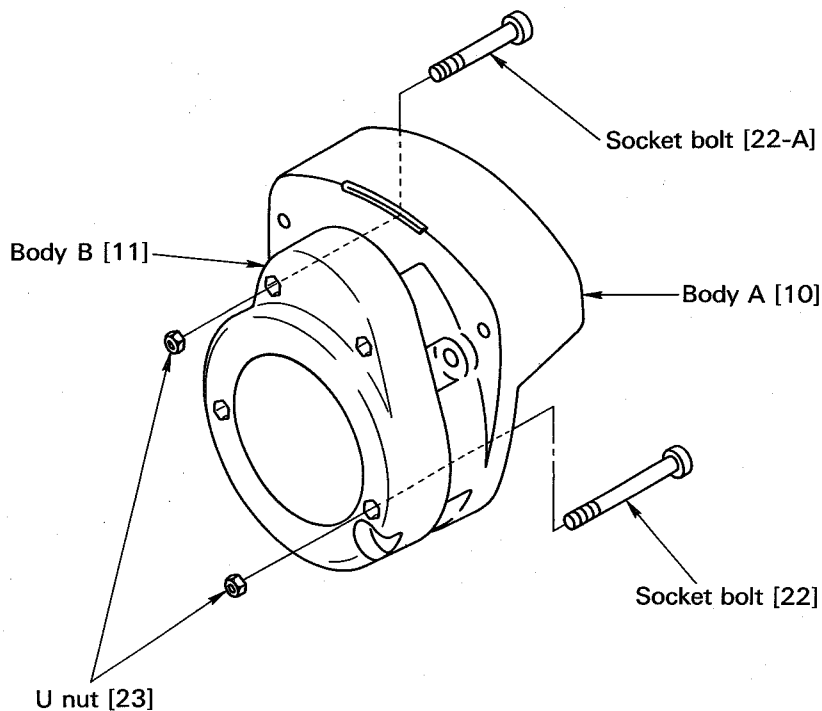
Assembly Procedures

Remarks

12. Grease ball bearing A [15] and insert it into the body A [10].

13. Put the body A [10] with the ball bearings [15,17-A] side down on the body B [11].

14. Insert four socket bolts [22,22-A] into the body A [10] and turn the whole body sideways. Then fix the bolts with the U nuts [23] holding the U nuts with fingers.



15. Insert pawl pin [24] into the body A [10] and fix it with the U nut [25].

16. Apply machine oil to the pawl pin [24] and join pawl spring [26] and the pawl [27] respectively to it. Fix the pawl with snap ring [28].

⚠ WARNING

Make sure each part is completely set between body A [10] and frame [13].

⚠ WARNING

Insert short socket bolts [22-A] to the upper holes and long socket bolts [22] to the lower holes.

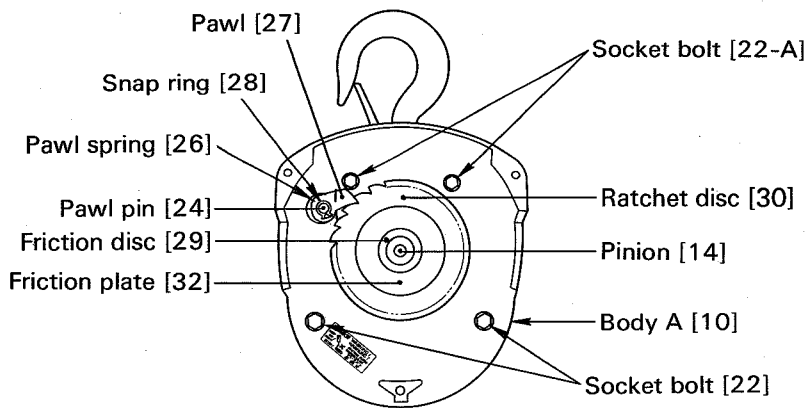
⚠ WARNING

Make sure the pawl spring is fixed to the pawl and the snap ring is securely set at the groove of the pawl pin.

Assembly Procedures

Remarks

17. Put friction disc [29] to the pinion [14].
18. Wipe out any dirt on the friction disc [29], friction plates [32] and both sides of the ratchet disc [30] and check that bushing [31] contains oil soaked inside. Then place the friction plate, bushing, ratchet disc (while turning the pawl [27] counterclockwise) and friction plate respectively on the friction disc. (Make sure that the pawl meshes with the ratchet disc properly.)



19. Wipe out the dirt of the hand wheel [33] and apply machine oil to the threaded part of it. Screw it in the pinion [14] shaft all the way down.
20. Place wheel stopper [34] to the head of the pinion [14], insert wheel stopper pin [35] and fix it with a split pin [36].

⚠ WARNING

Never apply oil since the brake is “dry system”. Wipe out thoroughly any oil and dirt on the brake. The gear of the ratchet disc shall point at the pawl. Otherwise, the hand wheel cannot be assembled later.

In case the bushing does not have oil inside, soak it in tarbin oil for a day. Install it in without wiping the oil. Make sure that the pawl meshes with the ratchet disc properly.

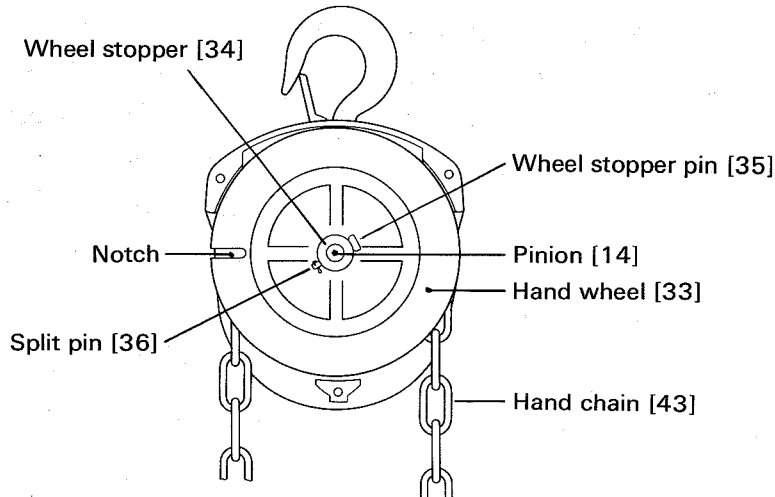
⚠ WARNING

Never forget to bend the split pin after inserting into the wheel stopper pin.

Assembly Procedures

Remarks

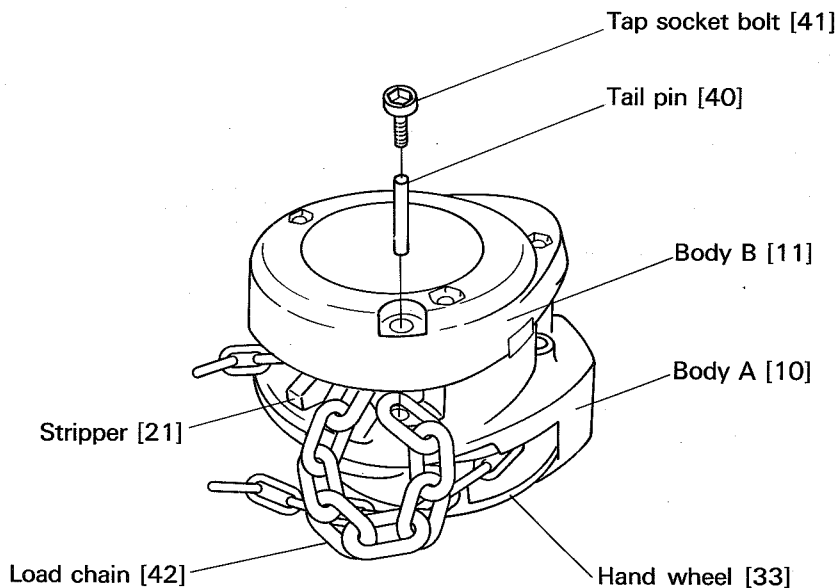
21. Set the notch of the hand wheel to the left hand. Insert the vertical link of the hand chain [43] into the notch of the hand wheel [33] and reeve the hand chain by turning the hand wheel clockwise.



22. Put wheel cover [37] on the body A [10] and fix them with the spring washers [39] and screws [38].
23. Put a hoist with body B [11] side up. Place the slack end of the load chain between body A [10] and body B [11]. Then insert tail pin [40], and screw tap socket bolt [41] into the body B.

⚠ WARNING

Make sure the load chain is not twisted.



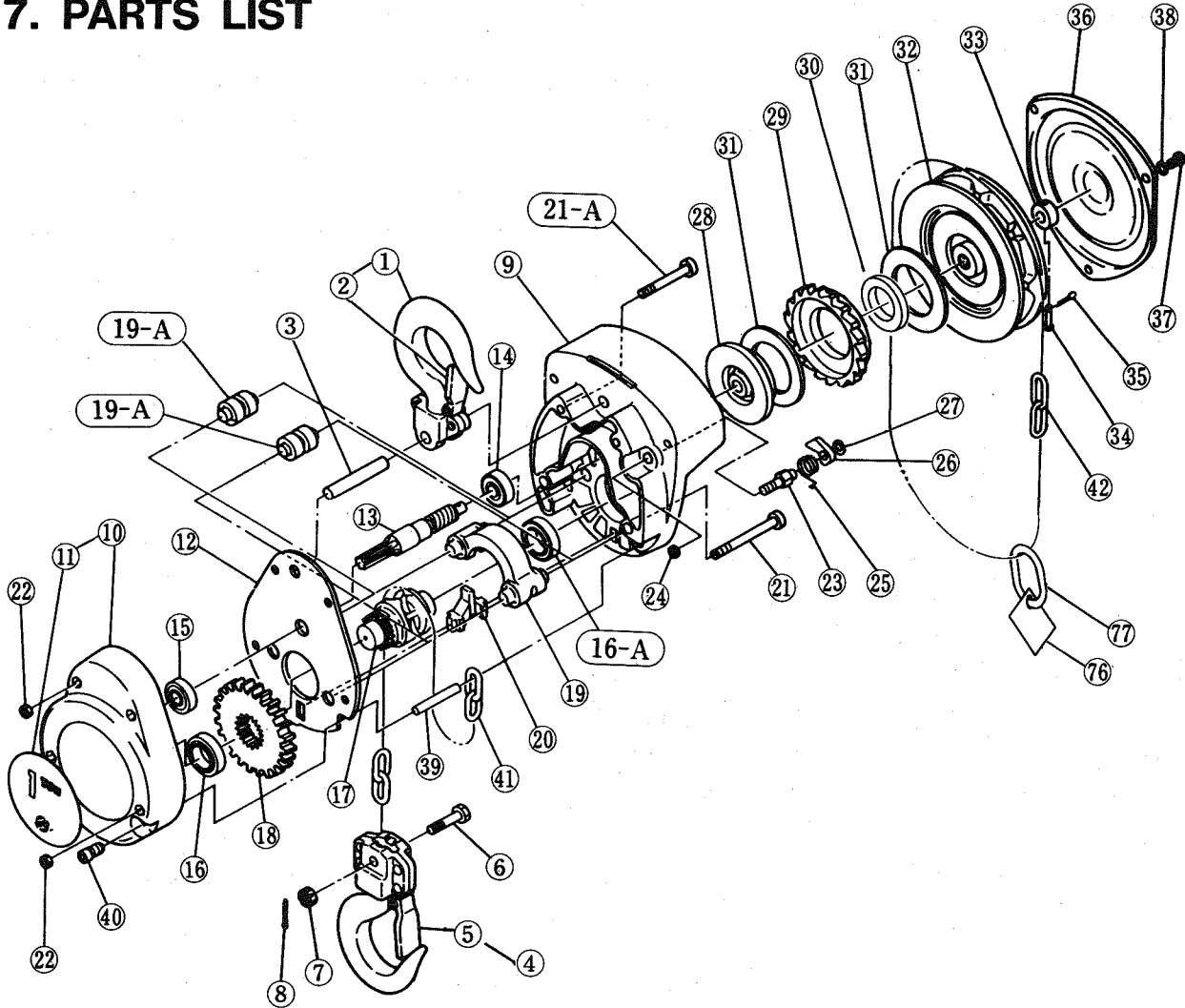
6. WARRANTY

Kito Corporation ("Kito") extends the following warranty to the original purchaser ("Purchaser") of new products manufactured by "Kito" (Kito's Products).

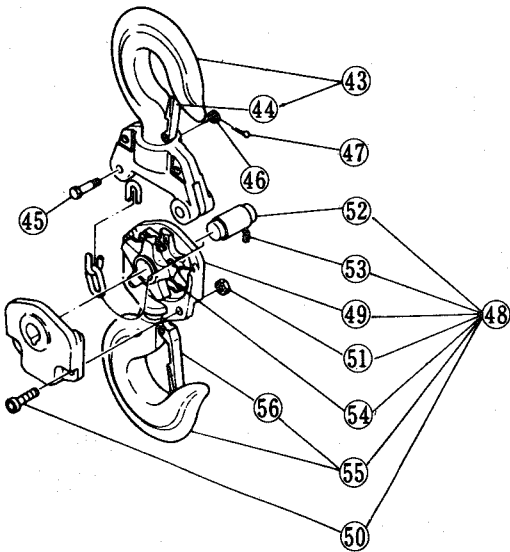
- (1) "Kito" warrants that Kito's Products, when shipped, shall be free from defects in workmanship and/or materials under normal use and service and "Kito" shall, at the election of "Kito", repair or replace free of charge any parts or items which are proven to have said defects, provided that all claims for defects under this warranty shall be made in writing immediately upon discovery and, in any event, within one (1) year from the date of purchase of Kito's Products by "Purchaser" and provided, further, that defective parts or items shall be kept for examination by "Kito" or its authorized agents or returned to Kito's factory or authorized service center upon request by "Kito".
- (2) "Kito" does not warrant components of Products provided by other manufacturers. However to the extent possible, "Kito" will assign to "Purchaser" applicable warranties of such other manufacturers.
- (3) Except for the repair or replacement mentioned in (1) above which is "Kito"'s sole liability and purchaser's exclusive remedy under this warranty. "Kito" shall not be responsible for any other claims arising out of the purchase and use of Kito's Products, regardless of whether "Purchaser"'s claims are based on breach of contract, tort or other theories, including claims for any damages whether direct, indirect, incidental or consequential.
- (4) This warranty is conditional upon the installation, maintenance and use of Kito's Products pursuant to the product manuals prepared in accordance with content instructions by "Kito". This warranty shall not apply to Kito's Products which have been subject to negligence, misuse, abuse, misapplication or any improper use or combination or improper fittings, alignment or maintenance.
- (5) "Kito" shall not be responsible for any loss damage caused by transportation, prolonged or improper storage or normal wear and tear of Kito's Products or for loss of operating time.
- (6) This warranty shall not apply to Kito's Products which have been fitted with or repaired with parts, components or items not supplied or approved by "Kito" or which have been modified or altered.

THIS WARRANTY IS IN LIEU OF ALL OTHER WARRANTIES, EXPRESS OR IMPLIED, INCLUDING BUT NOT LIMITED TO ANY WARRANTY OF MERCHANTABILITY OR OF FITNESS FOR A PARTICULAR PURPOSE.

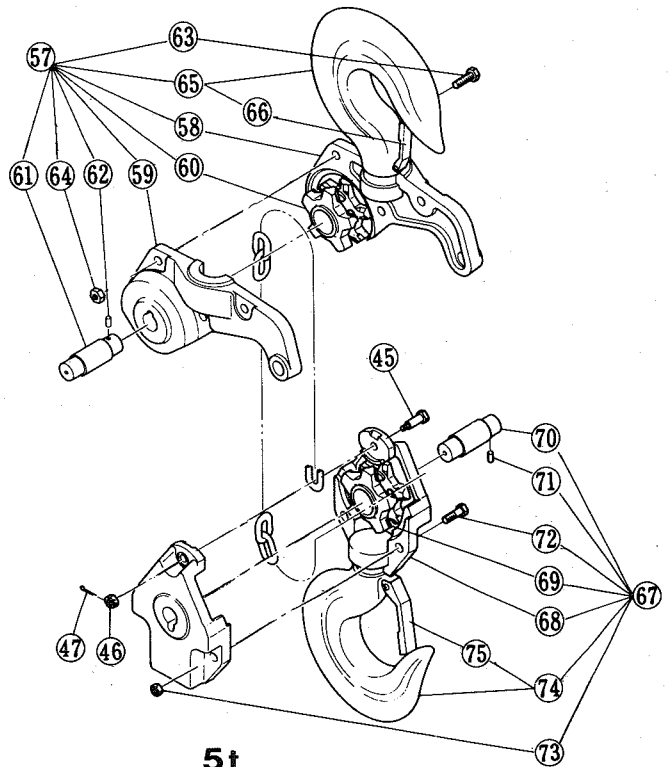
7. PARTS LIST



ADDITIONAL PARTS FOR 2, 3 AND 5 TON CAPACITY



2t, 3t



5t

Fig. No.	Part No.	Part Name	Nos. Per Hoist	Capacity Code					
				005	010	020	015	030	050
①	CF-001	Top Hook Assembly	1						
2	CF-071	Hook Latch Assembly	1						
③	CF-163	Top Pin	1						
④	CF-021A	Bottom Hook Complete Set	1						
5	CF-071	Hook Latch Assembly	1						
⑥	CF-041	Chain Pin	1						
⑦	CF-049	Slotted Nut	1						
⑧	CF-096	Split Pin	1						
⑨	CF-101	Body A	1						
⑩	CF-102	Body B with Name Plate	1						
11	CF-801	Name Plate	1						
⑫	CF-105	Frame	1						
⑬	CF-111AF	Pinion	1						
⑭	CF-120	Ball Bearing A	1						
⑮	CF-130	Ball Bearing B	1						
⑯	CF-140	Ball Bearing C	1						
⑰-A	CF-141	Ball Bearing D	1						
*⑰	CF-116	Load Sheave	1						
⑱	CF-114	Load Gear	1						
⑲	CF-178	Chain Guide (for 1t & over cap.)	1						
⑲-A	CF-161	Guide Roller (for 1/2t cap.)	2						
⑳	CF-162	Stripper	1						
㉑	CF-185	Socket Bolt for Body	2						
㉑-A	CF-186	Socket Bolt for Body	2						
㉒	CF-184	U Nut for Body	4						
㉓	CF-156	Pawl Pin	1						
㉔	CF-160	U Nut	1						
㉕	CF-158	Pawl Spring	1						
㉖	CF-155	Pawl	1						
㉗	CF-157	Snap Ring	1						
㉘	CF-153AF	Friction Disc	1						
㉙	CF-152AF	Ratchet Disc	1						
㉚	CF-154AF	Bushing	1						
㉛	CF-150AF	Friction Plate	2						
㉜	CF-115AF	Hand Wheel	1						
㉝	CF-159	Wheel Stopper	1						
㉞	CF-167	Wheel Stopper Pin	1						
㉟	CF-182	Split Pin	1						
㊱	CF-171	Wheel Cover	1						
㊲	CF-187	Screw	3						
㊳	CF-188	Spring Washer	3						

Fig. No.	Part No.	Part Name	Nos. Per Hoist	Capacity Code					
				005	010	020	015	030	050
㉞	CF-164	Tail Pin	1						
㊱	CF-181	Tap Socket Bolt	1						
㊲	CF-841	Load Chain	1						
㊳	CF-842	Hand Chain	1						
㊴	CF-931	Warning Tag	1						
㊵	CF-045	Chain Stopper Link	1						
ADDITIONAL PARTS FOR 2 & 3 t CAPACITY									
㊶	CF-001	Top Hook Assembly	1						
44	CF-071	Hook Latch Assembly	1						
㊷	CF-041	Chain Pin	1						
㊸	CF-049	Slotted Nut	1						
㊹	CF-085	Split Pin	1						
㊺	CF-021A	Bottom Hook Complete Set	1						
49	CF-031	Bottom Yoke	2						
50	CF-081	Bolt	2						
51	CF-082	Lever Nut	2						
52	CF-053	Shaft	1						
53	CF-083	Spring Pin	1						
54	CF-051	Idle Sheave	1						
55	CF-021	Bottom Hook Assembly	1						
56	CF-071	Hook Latch Assembly	1						
ADDITIONAL PARTS FOR 5 t CAPACITY									
㊻	CF-001A	Top Hook Complete Set	1						
58	CF-011	Top Yoke A	1						
59	CF-012	Top Yoke B	1						
60	CF-051	Idle Sheave	1						
61	CF-053	Shaft	1						
62	CF-083	Spring Pin	1						
63	CF-081	Bolt	3						
64	CF-082	Lever Nut	3						
65	CF-001	Top Hook Assembly	1						
66	CF-071	Hook Latch Assembly	1						
㊼	CF-021A	Bottom Hook Complete Set	1						
68	CF-031	Bottom Yoke	2						
69	CF-051	Idle Sheave	1						
70	CF-053	Shaft	1						
71	CF-083	Spring Pin	1						
72	CF-081	Bolt	2						
73	CF-082	Lever Nut	2						
74	CF-021	Bottom Hook Assembly	1						
75	CF-071	Hook Latch Assembly	1						

Note:

- *Load Sheave for 5 t cap. is delivered complete with Load Gear.
- The letter "AF" in parts list means exclusive use for Model CF4. When ordering parts for Model CF3, use same part name and parts number without AF.
- CF-154AF Bushing is exclusive for CF4.

NOTES



KITO CORP.

3-37-4, Yoyogi, Shibuya-ku,
Tokyo 151-0053, Japan

Tel. : 03-5371-7341

Fax. : 03-5371-7349

Tlx. : 222-2942 KITO J

E-mail : overseas@kito.co.jp

URL [http : //www.kito.co.jp](http://www.kito.co.jp)